



Engineering, Integration,
Manufacturing and
Exclusive Provider of
Dr. Pharm Equipment
in the USA
DENVER

Dr. Pharm USA

866.778.7826

Global Equipment
Supplier to the
Pharmaceutical and
Supplement
Industries
BEIJING

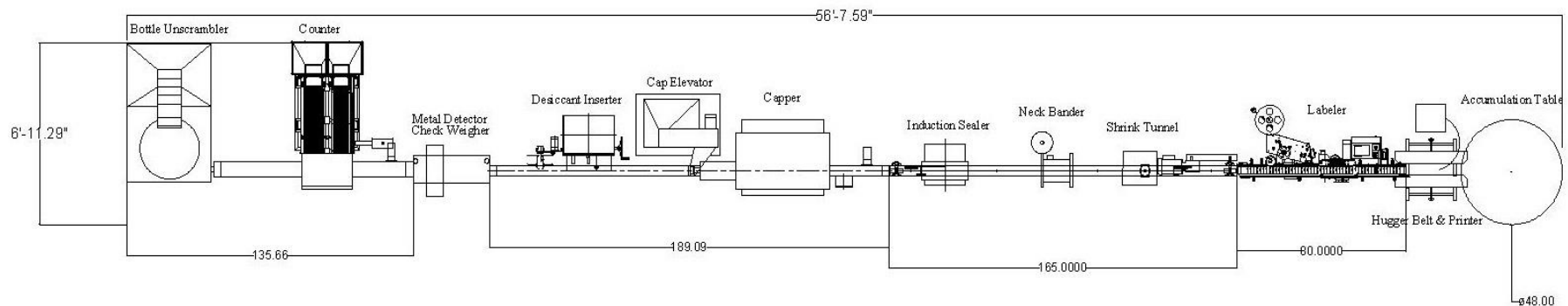

Our Mid-Level Counting Line is designed to run at ~50-60 bpm (60 count)
Capable of counting a variety of products

Mid-Level Counting Line



Engineering, Integration,
Manufacturing and
Exclusive Provider of
Dr. Pharm Equipment
in the USA
DENVER

Dr. Pharm USA

866.778.7826

Global Equipment
Supplier to the
Pharmaceutical and
Supplement
Industries
BEIJING



Typical Mid Level Counting Line Configuration;

RATE	50-60 BPM (60 COUNT)
Rough Dimension	56' x 7'
Unscrambler	<120 bpm
Conveyor Section #1	150+ bpm
Pacing Wheel	150+
Counter	100 bpm
Hugger Belt #1	150+ bpm
Metal Detector	<150 bpm
Check Weigher	<150 bpm
Rejecter	<150 bpm
Accumulation Table #1	For Rejecter 150+ bpm
Conveyor Section #2	150+ bpm
Cottoner or Desiccant Inserter	Cottoner <100 Desiccant <150
Capper	<150 bpm
Induction Sealer	<150 bpm
Conveyor Section #3	For Neck Band Sealer 150+
Neck Band Applicator	<100 bpm
Shrink tunnel	<150 bpm
Printer (CIJ)	Expiry Date & Lot No. 150+ bpm
Hugger Belt #2 for Printer	150+ bpm
Labeler	<155 bpm
Accumulation Table #2	For Finished Bottles 150+ bpm

Options:

- Vision System
- Case Sealer
- Cocked or Missing Cap Detector

Included Items

- Engineering
- Control Panels
- Shipping
- Pacing Wheel

Cost: \$382,720

(Based on recommended configuration)

Mid-Level Counting Line